







Regulated Filter Head

FDS-RFH-ASM



-  Hard coat anodized for durability
-  Tested to 3,000 liters per hour
-  4-port fuel distribution block
-  Donaldson 3-micron fuel filter included
-  Pre filter and post filter pressure ports
-  Built in pressure regulator

The S&S Diesel Motorsport® Regulated Filter Head is a compact unit that features a built-in pressure regulator, stock Cummins mounting flange, filter in and out pressure ports, and a fuel distribution block.

The filter head design keeps durability in mind with multiple key features: steel insert for filter threads, hard coat anodizing to prevent oxidation and wear in the regulator, and a billet 6061 aluminum body.

The Filter Head is designed to pair with the S&S Diesel Motorsport SP3000 to create the Fuel Delivery System, which will support applications ranging from 400 to 4,000 horsepower.

Multiple springs are supplied to be able to use the filter head for a variety of applications. The regulator port can simply be blocked off if only filtration is needed.

Technical Specifications

Fuel Compatibility	Diesel
Weight (No filter)	752 g (1.65 lbs)
Maximum Dimensions	See Drawings
Max Flow	3000 L/hr
Fuel Temperature	-40° to 70°C
Working Pressure	Up to 240 psi
Available Regulator Springs	5, 15, 120, 140, and 180 psi

Application

Daily Driver to Race Vehicle

Filter Specifications

Included Filter	Donaldson P551311 or P551313
Efficiency	99% at 3 Micron
Media Type	Cellulose
Maximum Delta P (Collapse Rating)	100 psi

Key Features

Inlet pressure sensing ports (1/8 npt)
Outlet pressure sensing port (1/8 npt)
Works for all CP3 Configurations
Pressure Regulator design optimized for zero chatter operation
Steel and Aluminum Construction

Quick Start

Keys to Success

- ☞ Use -8AN hose for the suction (inlet) and pressure (outlet) ports of the SP3000
- ☞ Each inlet is labeled for the direction of the CP3 shaft rotation (FWD-IN and REV-IN)
- ☞ Use -8AN hose on the -8AN return fitting of the Regulated Filter Head
- ☞ Must use the provided -8AN to -8ORB (Fragola P/N 495103-bk) fitting in the return port of the filter head to properly set the pressure for the low side fuel system (DO NOT USE ANY OTHER FITTING)
- ☞ Tee the return line into the suction line of the SP3000 to help with fuel pressure regulation and fuel foaming

OPTIONAL

- ☞ Install pressure sensor (sold separately) on port labelled OUT to monitor post-filter pressure
- ☞ Install pressure sensor (sold separately) on port labelled IN to monitor pre-filter pressure

Priming Instructions

- 1) Fill the fuel filter with diesel fuel
- 2) Hand-tighten fuel filter until gasket touches the base, then another $\frac{3}{4}$ turn (270 degrees)
- 3) Pressurize the fuel tank if it is lower than SP3000 | Rely on gravity if the fuel tank is higher
- 4) Crack the suction line directly at the SP3000 inlet until fuel comes out, then tighten
- 5) Crack the low-pressure supply line directly at the CP3
- 6) Crank the engine until fuel comes out, then tighten
- 7) Ready to start the engine

Detailed Information

Hose sizing: Keep in mind length and ID of the hose will affect flow. It is also important to run a -8 return hose from the regulated filter head back to the supply pump suction line. If there are any restrictions in the return line, this will cause the main pressure to rise above our safe margins. There are three -6 and one -8 outputs to supply regulated fuel to your high-pressure fuel pump(s). In most cases we only need two -6 lines to supply the high-pressure pumps. You can run -8 with no problems but we haven't seen any benefits.

Return Side: It is important to use a dedicated -8 return line from the filter head and tee into the -8 suction line (reference routing diagram). This will help keep pressure stable and prevent fuel foaming. It is also just as important to use the provided -8AN to -8ORB fitting (Fragola p/n 495103-bk) because the depth of the taper helps determine seat pressure on the regulator nipple. Using a different fitting will cause pressure and spring force change. The high-pressure fuel pump, injector and relief valve return lines would be best if ran separately back to the tank with -6 line for each item. If space is limited, size up the return line when combining with "Y" fittings. Remember that return restrictions are just as critical as low fuel pressure. Any foreign pressure on the backside of the injector can cause anything from erratic idle, misfires, to solenoid separation depending on how sensitive your system is.

Filter: Donaldson P551311 (9" tall) or Donaldson P551313 (7" tall) only. Before installing the filter, fill with diesel fuel and lube the o-ring with the fuel used to fill. Spin the filter on to the base until the lubed sealing ring makes contact with the base and rotate another 270 degrees or $\frac{3}{4}$ turn, it will be tight. You can use the arrows near the top of the filter to help. Solid arrow, triangle, square and circle within the arrow, to easily see 270 degree or $\frac{3}{4}$ of a turn. Once vehicle is running and the filter has seen multiple heat cycles, check the filter with the same emphasis it took to get to the 270 degree or $\frac{3}{4}$ turn. Vehicles with higher vibrations we recommend a small marking from filter head to filter so a quick visual glance can provide mental security.

Pressure Ports: There is IN and OUT pressure ports on the regulated filter head. Most applications will utilize the OUT port to see the fuel pressure being supplied to the high-pressure fuel pump(s). In some cases, you can utilize the IN port to see filter restrictions and configure service intervals. Most high-performance racing applications won't utilize the IN port.

Regulated Filter Head: It comes with a 180psi spring pre-installed and can run up to 240psi while working. The pressure can change vehicle to vehicle depending on the return system sizing, length and fuel mixtures. Changing the pre-installed AN fitting on the return port will also affect supply pressure. It's recommended to use that fitting only. 5psi and 15psi springs are included to be utilized with electric supply pumps and stock CP3 gear pumps. Duramax-based pumps are more sensitive to supply pressure and require the 5psi spring. The 15psi spring is designed for Cummins/Ram applications.

Flow Data

Spring Selection Guide

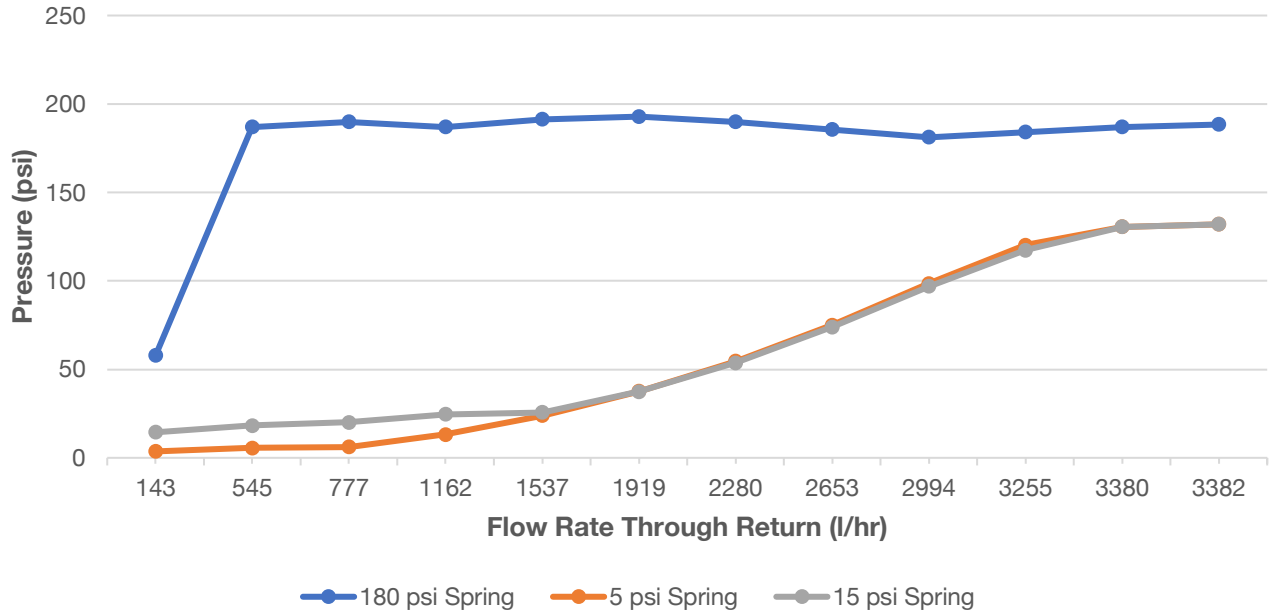

Flow Rate vs Pressure Drop Across the Filter

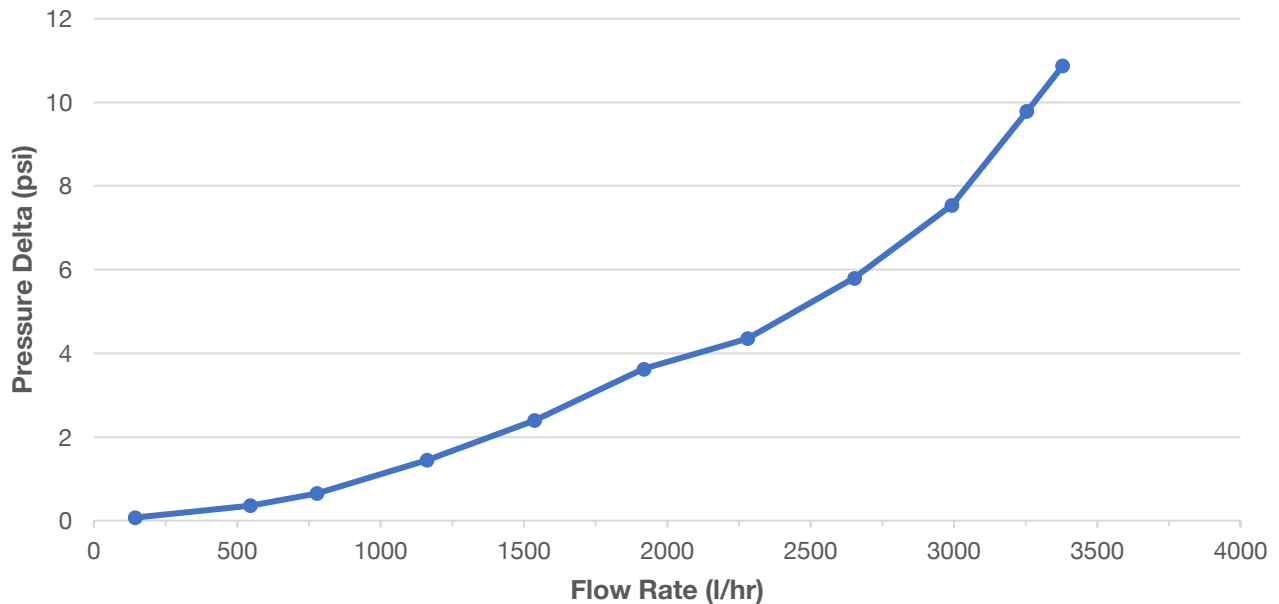

Pump Suction Hose and Fitting Sizing

The graphs below will determine the recommended supply pump suction hose size for various high-pressure pump configurations. The recommended safety factor is 20%.

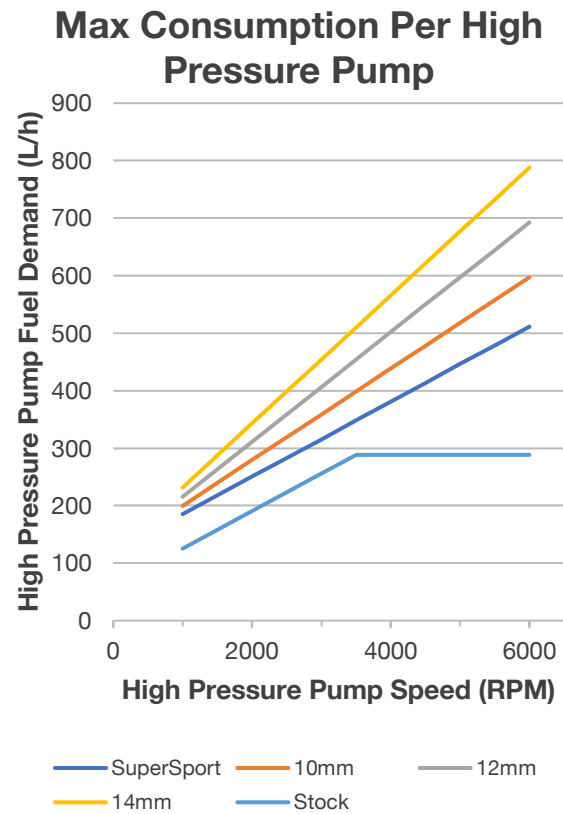
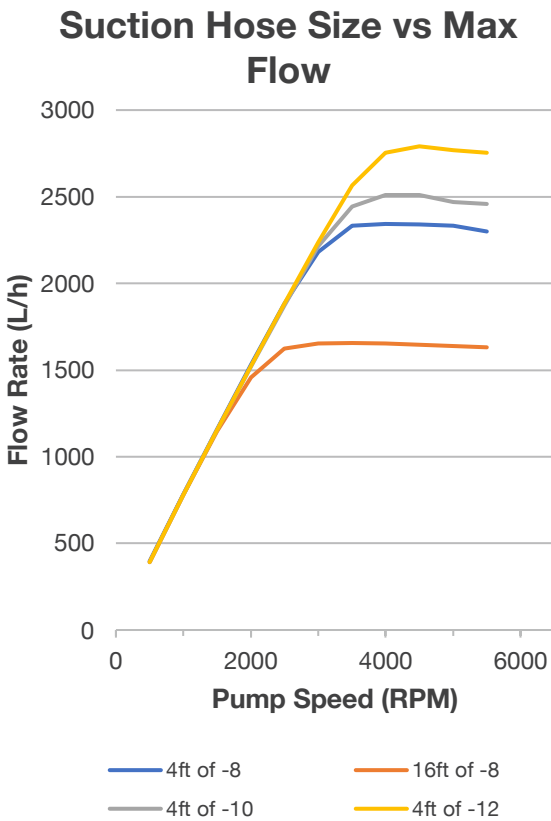

Example: The supply pump needs to support (2) 12mm high pressure pumps up to 5,000 rpm.

One 12mm pump consumes 600 L/h, so two pumps consume 1,200 L/h, and a safety factor of 20% should be used. Therefore, the supply pump suction hose needs to support 1,440 L/h ($1,200 \times 1.2 = 1,440$). Then find the 1,440 L/h point on the Suction Hose Size graph and select the line that is above that point. In this case, **16 FT of -8 AN** hose will support that requirement.

Mounting Pattern

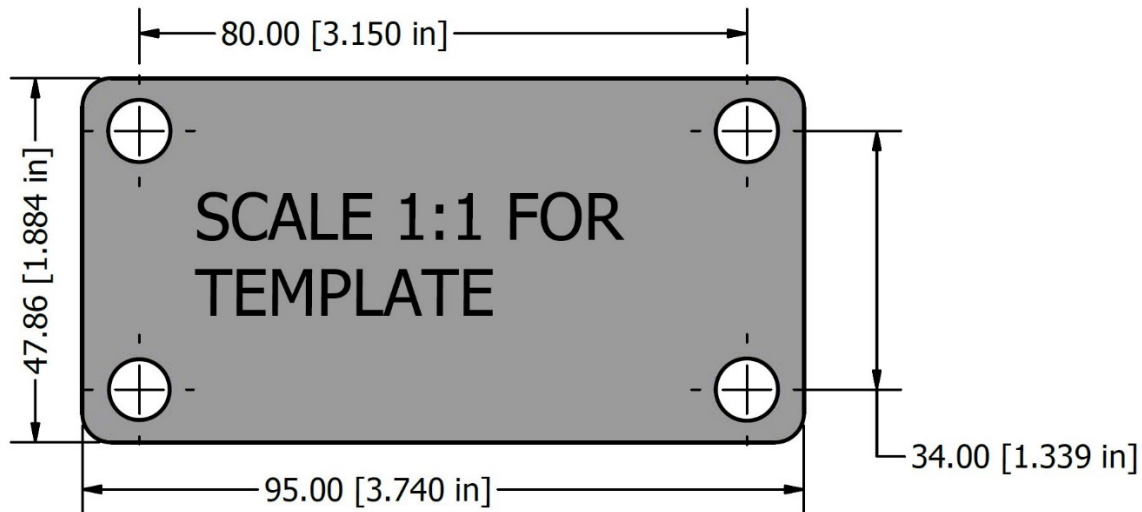

Note: Make sure to set printer at 100% scale when printing the template, and confirm measurements.

Spring Selection

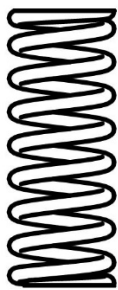

180 psi Spring



15 psi Spring



5 psi Spring

Drawings

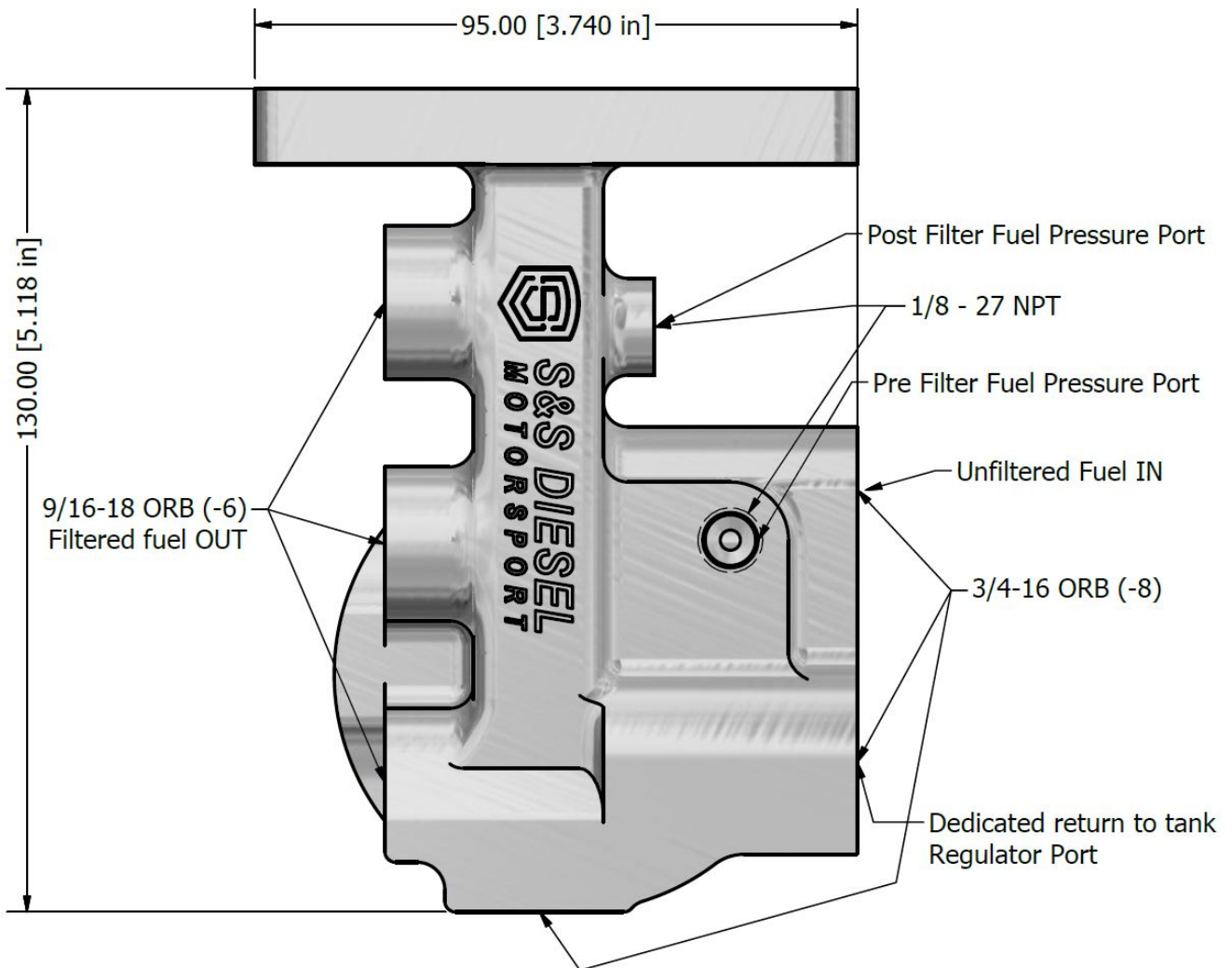

Drawings Continued

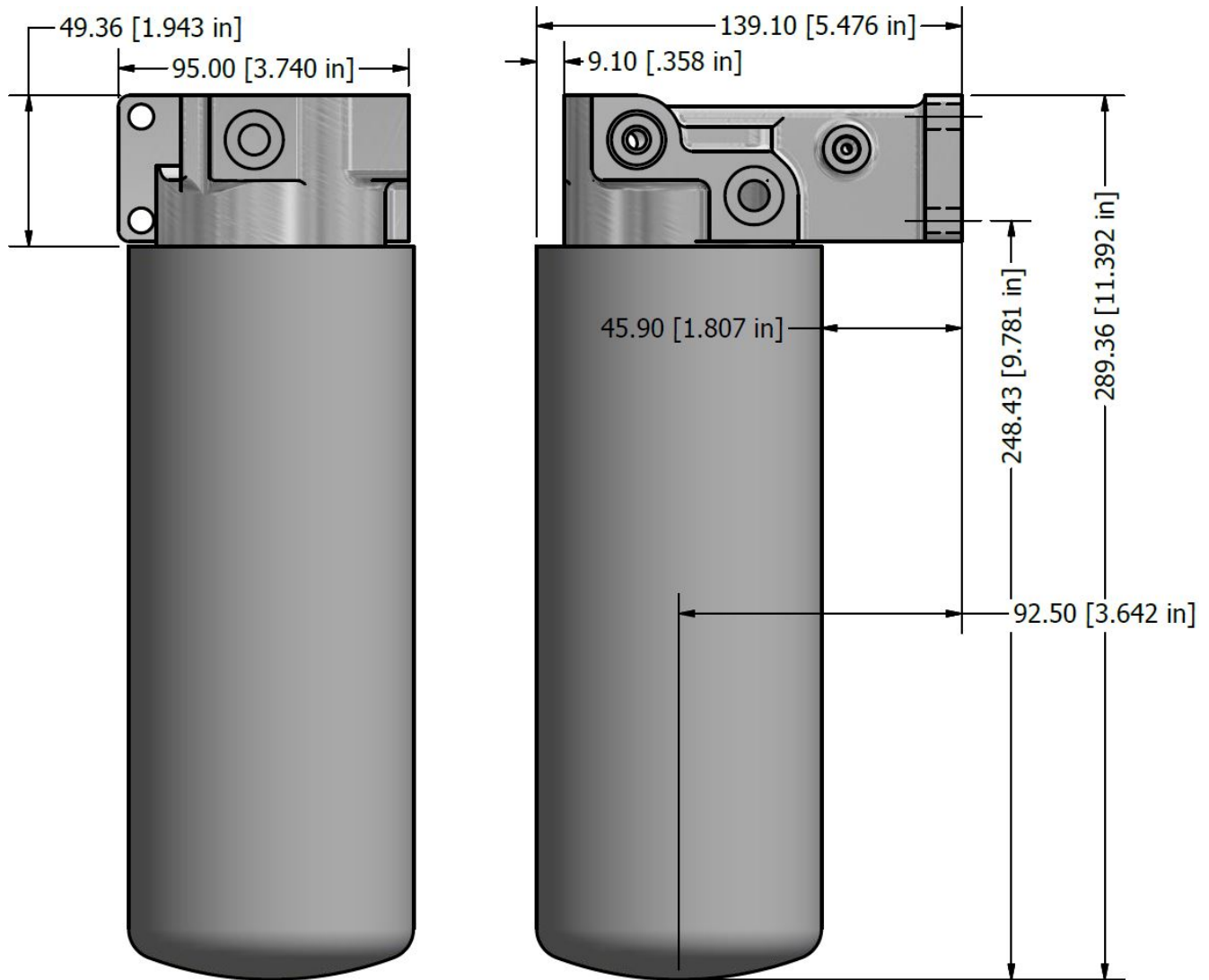

Routing Diagram

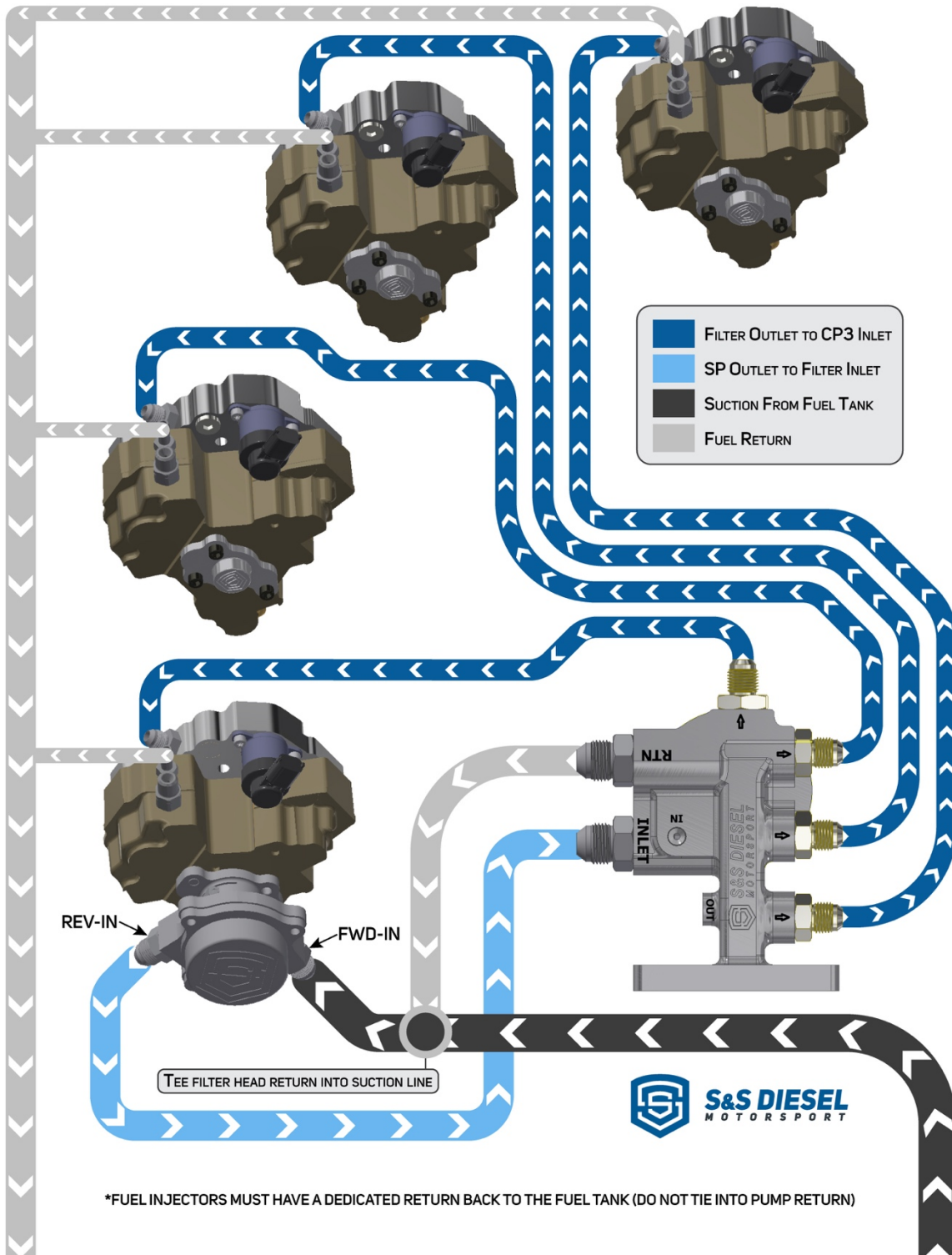

*FUEL INJECTORS MUST HAVE A DEDICATED RETURN BACK TO THE FUEL TANK (DO NOT TIE INTO PUMP RETURN)