



# S&S DIESEL

MOTORSPORT

## CP4 to DCR Pump Conversion – Ford 6.7L Power Stroke

Vehicle Fitment: 2011-2024 Ford Super Duty equipped with 6.7L Power Stroke Diesel

**Part Number: 6.7F-DCR-1**

CARB EO: D-756-7 (2011-2023)

SEMA Certificate of Compliance: SC-SDM01-0034

### Installation Instructions



**Parts Included in Ford 6.7 CP4 to DCR Pump Conversion Kit:**

Please verify that all components stated below are included in the kit you received:

- S&S DCR High Pressure Fuel Pump - 1x
- High Pressure Fuel Line for Driver Side Pump Outlet Fitting – 1x
- High Pressure Fuel Line for Passenger Side Pump Outlet Fitting – 1x
- Low Pressure Fuel Supply & Return Line Assembly – 1x
- Plastic Clip for Low Pressure Line Assembly (ships with water in the bag to keep the clip flexible) – 1x
- Adapter Plate – Engine Block to DCR Pump – 1x
- Adapter Plate Mounting Bolts - T45 Torx Countersink Head – 2x
- Adapter Plate Studs – 2x
- Pump Tail Support Bracket for High Pressure Fuel Lines – 1x
- Plug for Supply Line for model years 2015+ – 1x
- Sensor Adapter for model years 2015-2019 – 1x
- Vibra-Tite 122 Medium Strength Thread-locker – 1x

**Critical Torque Specifications:**

Part Description		Standard	Metric	Blue Threadlocker
Pump Gear Nut		60 lb-ft	81 Nm	
Adapter Plate – T45 Torx Countersink Mounting Bolts - <i>Lubricate the under head (see Figure 23)</i>	Initial Torque Final Torque	10 lb-ft 42 lb-ft	14 Nm 57 Nm	Yes
Adapter Plate – Studs into the Adapter Plate		Hand Thread into the plate until they bottom out		Yes
OEM Pump Mounting Nuts x3	Initial Torque Final Torque	10 lb-ft 18 lb-ft	14 Nm 25 Nm	Yes
High Pressure Fuel Line Nuts		26 lb-ft	35 Nm	
High Pressure Fuel Line Clip Bolts		89 lb-in	10 Nm	
Return Fuel Line to Valve Cover Bolts		89 lb-in	10 Nm	
Fuel Supply Line Assembly to DCR Pump - OEM Bolt		89 lb-in	10 Nm	Yes
Vacuum Pump - OEM Bolts		89 lb-in	10 Nm	Yes
Fan Clutch to Fan Pulley		98 lb-ft	133 Nm	

**Change Log:**

- Rev 00 - Initial Release
- Rev 01 – CARB approval & Two-Step Pump Mounting Torque Process
- Rev 02 – Vibra-Tite pump studs for the three OEM mounting nuts and added pump timing with shaft roll pin
- Rev 03 – T45 Torx bolts: Two-Step and increase torque to 42 lb-ft

**Tools Needed for Install:**

- ¼", ⅜" and ½" Drive Ratchets
- 8mm through 15mm Shallow and Deep Sockets
- 27mm Deep Socket (Pump Gear Nut)
- 24mm Deep Socket or Wrench (Fuel Supply Line Pressure Sensor)
- 18mm 12-point Socket (Crankshaft damper bolts to rotate the engine when timing the fuel pump)
- 17 and 19mm Crows Foot Line Wrench or short Line Wrench Socket (High Pressure Fuel Lines)
- T45 Torx Bit Socket (DCR adapter plate countersink bolts)
- Various ¼" and ⅜" Drive Extensions
- 3/8" Breaker Bar, Long Ratchet, or Belt Tensioner Tool
- 3/8" Torque Wrench
- Flathead Screwdriver
- 8mm through 17mm Wrenches or Ratchet Wrenches
- Blue Primerless Medium Strength Thread-locker – Loctite 243 or Vibra-Tite 122 (Provided in the DCR Kit)
- O-Ring Lubricant – Engine Oil, P80 Emulsion Assembly Lubricant, Ultra Lube, etc
- Fan Pulley Holding Tool (Ford 205-036) and 47mm Wrench (Ford 303-214) to remove the fan
  - *Merchant Automotive Fan Clutch Wrench (PN: 10358), long ½" Extension, and Air Hammer works well*
- Straight and 90-degree Pick
- 5/16" Fuel Line Disconnect Tool (2017+ only)

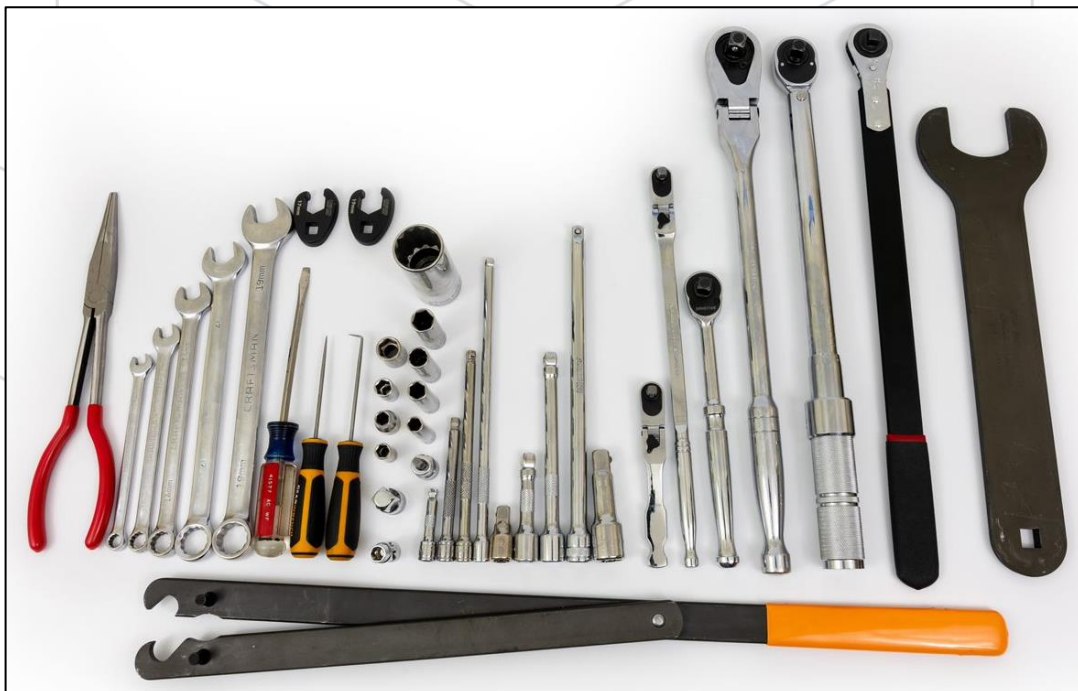

### Replacement Ford Part Numbers:

On 2011-2016 trucks, we recommend replacing the Vacuum Pump Gasket. All other seals, gaskets, and hardware listed here can typically be reused.

- Vacuum Pump Gasket: BC3Z-2A572-A / Mahle B32630 / **S&S 6.7F-VAC-GASKET**, BC3Z-2A572-B

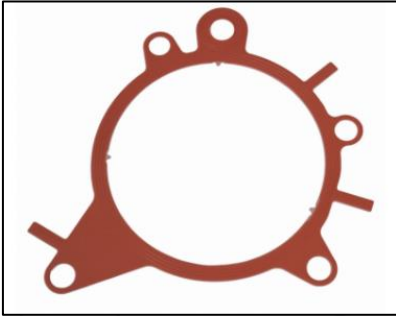

Figure 6: BC3Z-2A572-A for 2011 – 2016 models

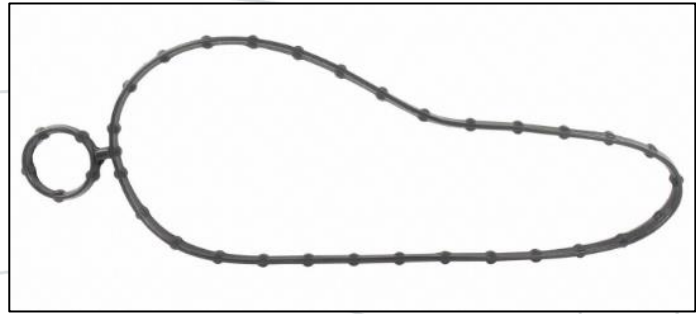

Figure 7: BC3Z-2A572-B for 2017 – 2024 models

- Intake Manifold Gasket: BC3Z-9439-A, BC3Z-9439-B, BC3Z-9439-C

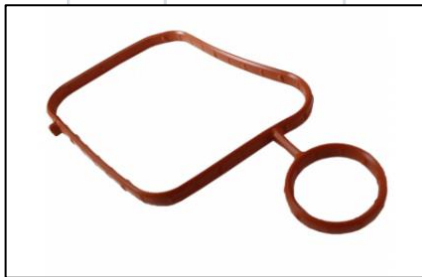

Figure 1: BC3Z-9439-A



Figure 2: BC3Z-9439-B

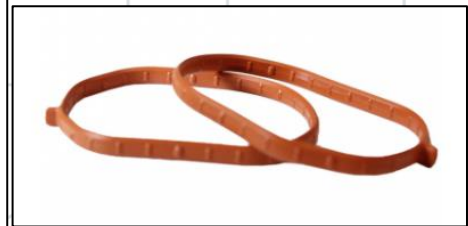

Figure 3: BC3Z-9439-C

- Bypass Valve Gasket: BC3Z-9E464-F & Pump Mounting Stud/Nut: BC3Z-9N943-A



Figure 4: BC3Z-9E464-F



Figure 5: BC3Z-9N943-A

Before removing any components from the engine bay, use compressed air or low-pressure water to clean any debris out of the engine bay. During installation there will be the opportunity for contaminants to get into the engine's air, oil, and fuel circuits.

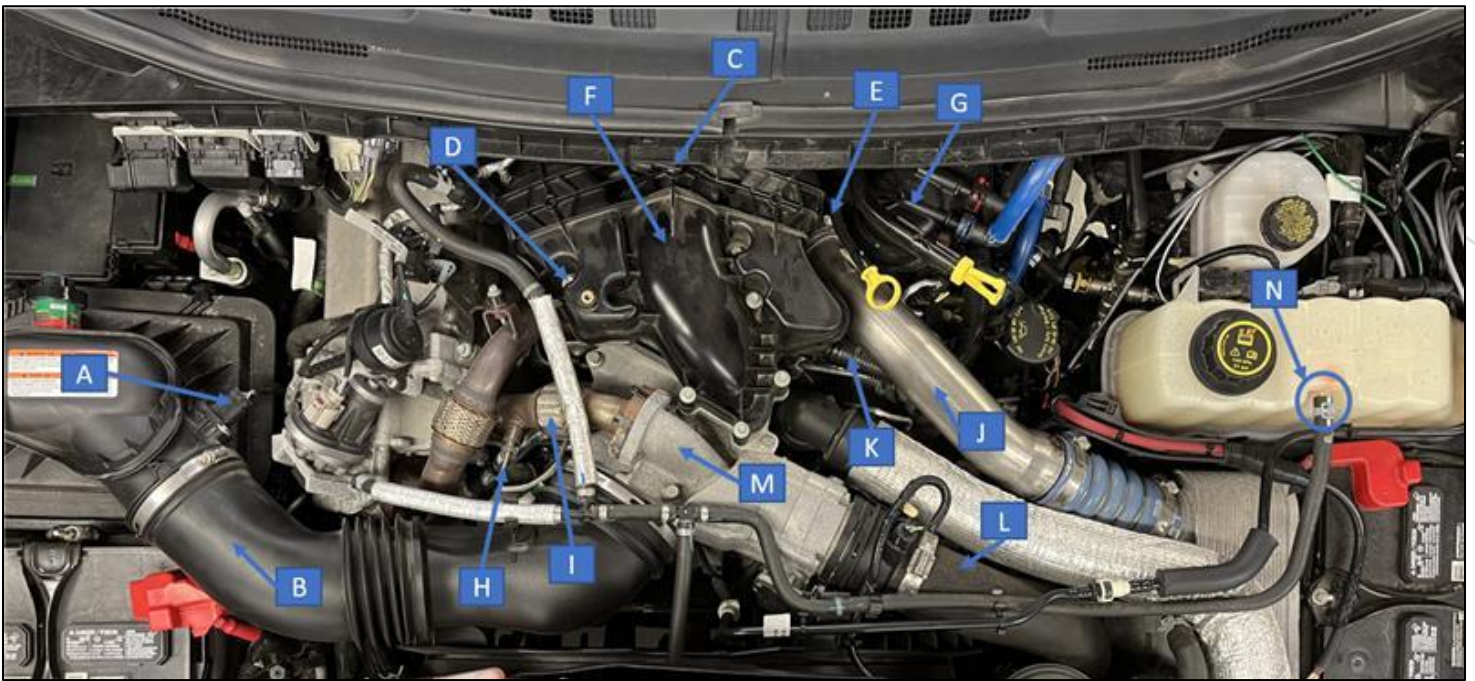

Figure 8: Engine Component Diagram (MY 2017-2019 shown)

#### CP4 Removal Instructions:

1. Disconnect the negative battery cable from both batteries.
2. Referring to Figure 8 above, unplug the MAF sensor (A) & remove the air filter intake pipe (Labeled as B).
3. Remove the coolant fill cap SLOWLY to remove residual pressure. Clamp the rubber hose & disconnect the coolant line on the coolant tank and place the line over the passenger side battery area. (Labeled as N)
4. Unplug the MAP sensor on the top of the upper intake manifold (Labeled as C).
5. Remove the coolant and vacuum hose retainer from the upper intake manifold (Labeled as D).
6. Unbolt the transmission and oil dipstick from the upper intake manifold (Labeled as E).
7. Remove the fuel line that connects the fuel filter to the fuel pump's metal feed line. (Figure 9)



Figure 9: Fuel line is removed and not reused

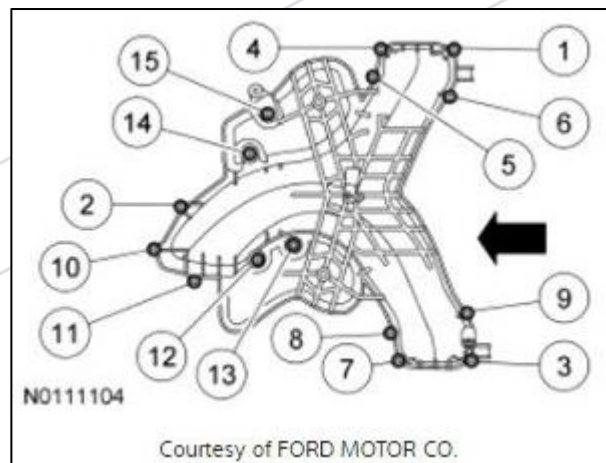

Figure 10: Upper Intake Tightening Sequence (MY 11-19)

8. Remove the hot side intercooler pipe (Turbo to intercooler pipe) (Labeled as J in Figure 8).
9. On all models, remove the fuel filter and fuel filter housing (Labeled as G in Figure 8).
10. Remove the upper intake manifold (Labeled as F in Figure 8). Keep track of bolt locations (Figure 10) as the bolts are different sizes.
  - a. On 2020+ models, the upper & lower intake manifolds are removed as a unit at Step 16.
11. Unplug the EGR temp sensor located in the EGR bypass outlet pipe (Labeled as H in Figure 8).
12. Remove the EGR bypass outlet pipe (Labeled as I in figure 8).
13. Remove the Crankcase Ventilation hose (Labeled as K in Figure 8) where it attaches to the lower intake manifold.
14. Remove the cold side intercooler pipe from the intake air throttle and the intercooler (Labeled as L in Figure 8).
15. Unplug the intake air throttle electrical connector.
  - a. On 2020+, unbolt the intake air throttle from the intake manifold to ease removing the upper and lower intakes as a unit.
16. Remove the lower intake manifold (Labeled as M).
17. Remove the top clips from the black fiber cover on the driver's side valve cover to gain access to the fuel lines.

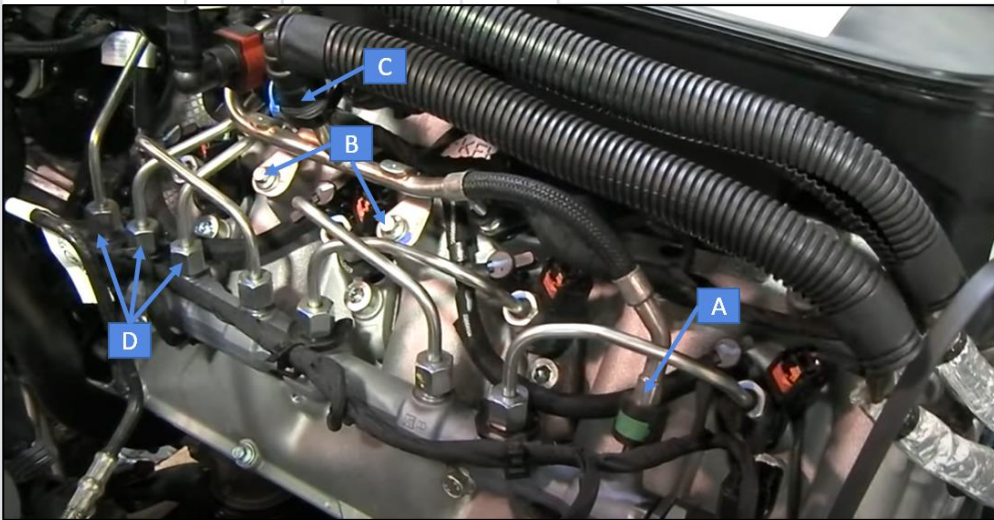

Figure 11: Fuel Line Connection Locations

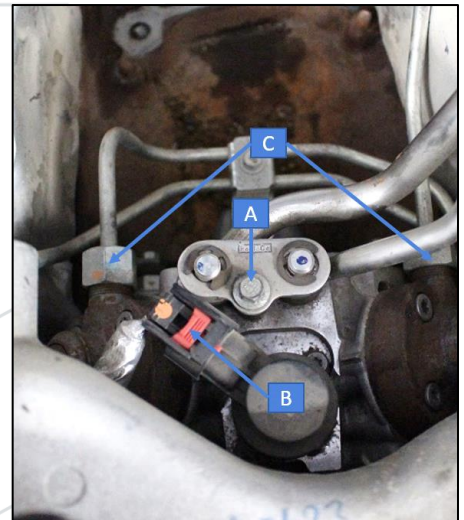

Figure 12: Fuel Lines to CP4 Pump

18. Referring to Figure 11 above, disconnect the low pressure return line from the fuel rail (Labeled as A).
  - a. 2011-2016 – Unlock the Green Quick Connect for removal
  - b. 2017+ - A 5/16" fuel line disconnect tool will be needed to remove this line
19. Remove the one or two bolts that attach the fuel return line to the valve cover (Labeled as B in Figure 11).
20. Disconnect the fuel return line to the fuel tank from the return line assembly (Labeled as C).
  - a. If a S&S DPK is installed, remove the return filter assembly & rotate the OEM quick-connect fitting (labeled as C in Figure 11) to the original OEM orientation, pointing downward. *(The S&S DPK return filter assembly can remain installed with the DCR pump).*

21. Referring to Figure 12, remove the hold down bolt (Labeled as A) connecting the line assembly to the CP4 fuel pump in the valley (this bolt will be reused with the DCR pump).
22. Unplug the sensors on the fuel inlet line (Figure 13).
- a. Note: 2011 - 2014 models have two sensors, 2015+ models have one sensor.
23. Unplug the electrical connectors for the driver's side front two injectors. *Use a pick to help release the lock tab.*
24. Remove the low-pressure fuel line assembly (Figure 14).
- a. The OEM sensor(s) in this assembly will be reused. They can be removed before or after line removal.

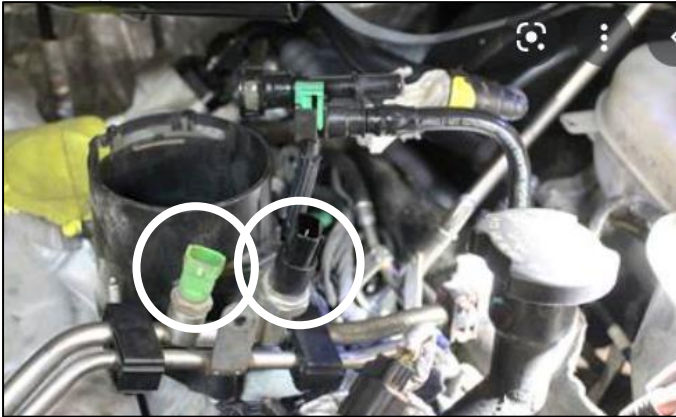

Figure 13: Fuel Supply Line Sensor Locations (MY 11-14 shown)



Figure 14: Low Pressure Fuel Line Assembly

25. Unplug electrical connector for the cooling fan clutch.
- a. Remove the top right bolt in Figure 17 holding the electrical bracket to the fan hub casting in Figure 16.
- b. Pull the bracket upward to free it from the rubber grommet and tuck the bracket and wire out of the way.
26. Remove the cooling fan (standard threads, counter-clockwise from the front) using the proper Ford fan tools or an air hammer with a 47mm fan tool attachment (see Tools section).
- a. The cooling fan can be left in the truck resting against the radiator. Use cardboard to protect the radiator.
- b. *NOTE: You can leave the fan connected to the bracket and remove the Fan Hub as an assembly if the fan is difficult to knock loose but the lower bolts are difficult to access with the fan on (Figure 17).*

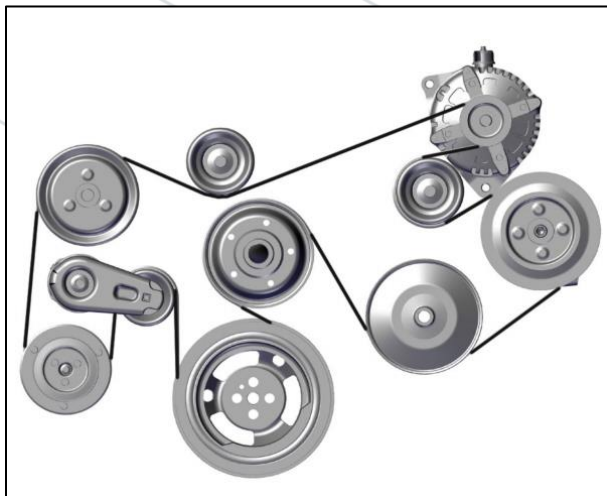

Figure 15: Belt Layout (Single Alternator)

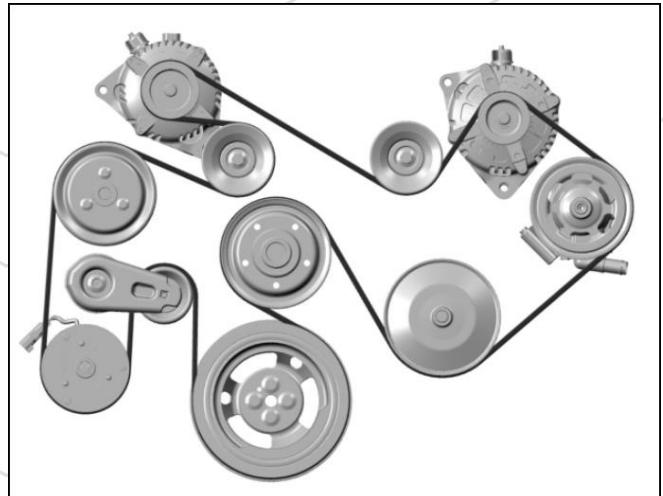

Figure 16: Belt Layout (Dual Alternator)

**27. Release tension on the accessory belt (Figure 15) & remove the serpentine belt.**

- a. Rotate the tensioner clockwise using a 3/8" ratchet to release the belt tension.

**28. Remove the remaining four bolts securing the cooling fan hub assembly (Figure 17).**

**29. Disconnect the vacuum line & remove the four 8mm bolts securing the vacuum pump (Figure 18).**

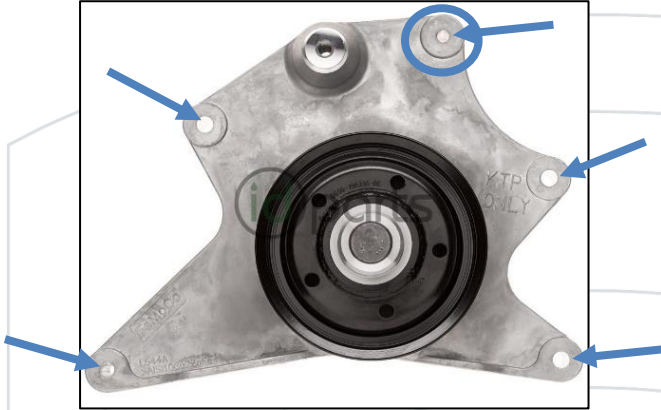

Figure 17: Cooling Fan Hub Bolt Locations

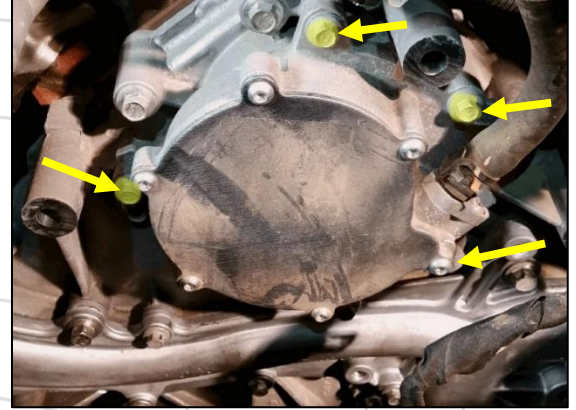

Figure 18: Vacuum Pump Bolt Locations

**30. Referring to Figure 12, unplug the fuel control actuator (FCA/VCV) electrical connector (Labeled as B in Figure 12) on top of the CP4 pump. The red locking tab slides back and then you push down on it to release.**

**31. Remove the oil fill tube by removing the bolt, rotating the tube 120 degrees counterclockwise, and then pull up.**

- a. It is optional to remove the oil fill tube but it eases the removal & install of the high-pressure lines.

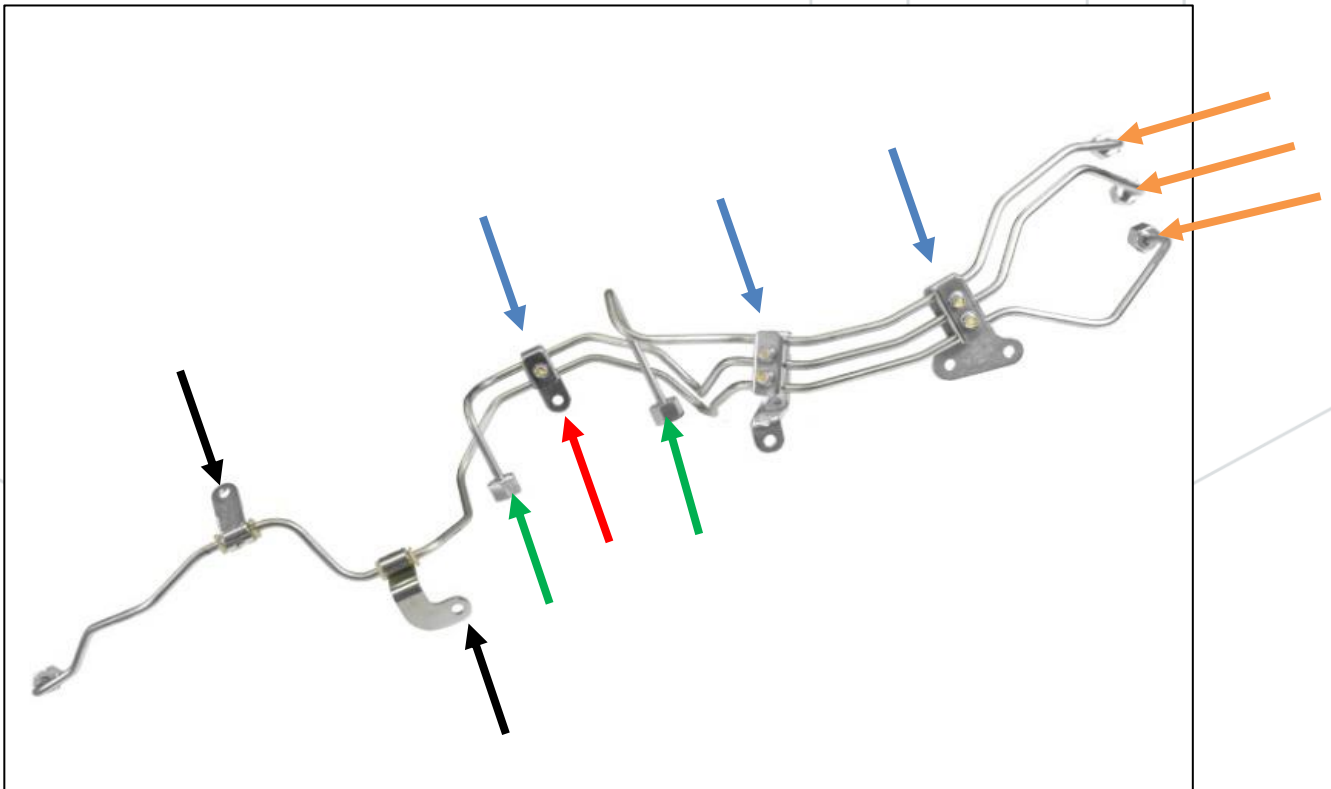

Figure 19: High Pressure Line Assembly Nut and Bolt Locations



### 32. Remove the high-pressure line assembly (The rail-to-rail high pressure line & two lines from CP4 to rail).

- The high-pressure line assembly to fuel rail connecting nuts are labeled as D in Figure 11 and colored in orange in Figure 19.
- The high-pressure line assembly to CP4 pump connecting nuts are labeled as C in Figure 11 and colored in green in Figure 19.
- Remove the five 8mm bolts holding the saddle brackets in place on the high-pressure line assembly colored in blue and the bolt for the rail-to-rail bracket colored in red in Figure 19.
- Remove the rail-to-rail crossover bolts below the EGR cooler colored in black in Figure 19 to allow the crossover line to be flexed towards the turbo compressor inlet.
- The rail-to-rail crossover line does NOT need to be removed or disconnected from the passenger side fuel rail. The line can be zip-tied towards the turbocharger to aid in CP4 fuel pump removal.

### 33. Fuel Pump Timing: Using an 18mm 12-point socket on the damper bolts, turn the crankshaft clockwise to roll the engine over until the single mark on the camshaft gear is facing upward as shown (Figure 20).

- Use a 27mm socket to remove the fuel pump drive gear nut. A quick jolt should knock it loose, else use an impact or hold the crankshaft.

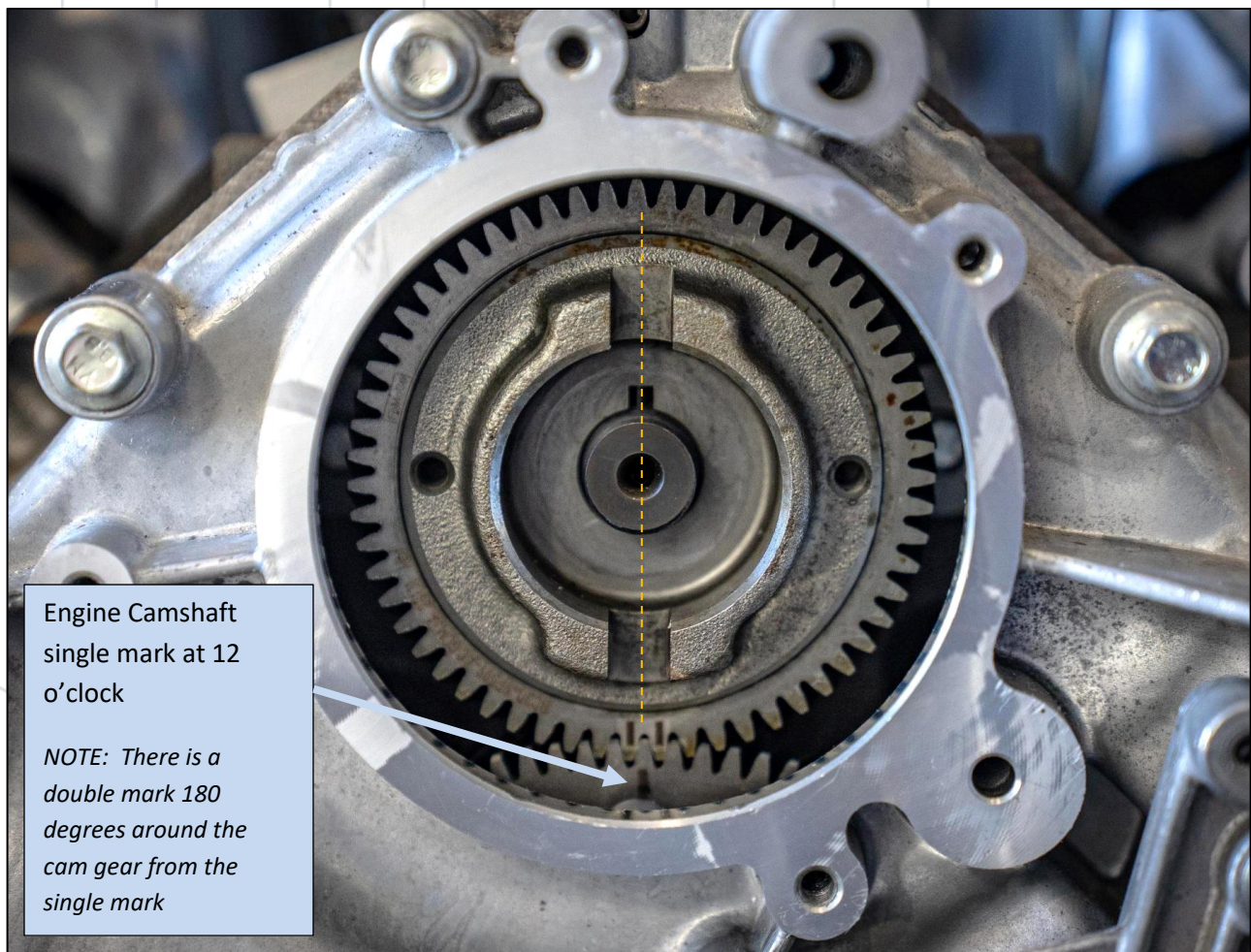

Figure 20: Rotate engine to TDC – Single Mark on the Engine Camshaft at 12 o'clock

34. Remove the three CP4 pump mounting nuts from the back of the pump using a 13mm socket.
35. Remove CP4 pump from the engine by gently striking the CP4 camshaft nose to separate the pump from the gear as the gear is a taper-fit and thus requires some force to separate.
  - b. Remove the gear and inspect the gear / gear teeth to ensure they are not damaged as the OEM gear will be reused with the new DCR pump.

### DCR Pump Installation:

1. Remove the upper two 15mm CP4 mounting bolts (Figure 21). Be careful not to drop the mounting bolts in the front cover. It is a tight fit, but the bolts can be removed through the CP4 gear cover hole.
  - a. *Tip: A 15mm crows-foot or u-joint socket works well for this.*
  - b. *Tip: To aid in getting the bolt head to clear the front cover hole, continue to turn the bolt counter-clockwise by hand while removing the bolt to prevent the bolt from getting wedged.*

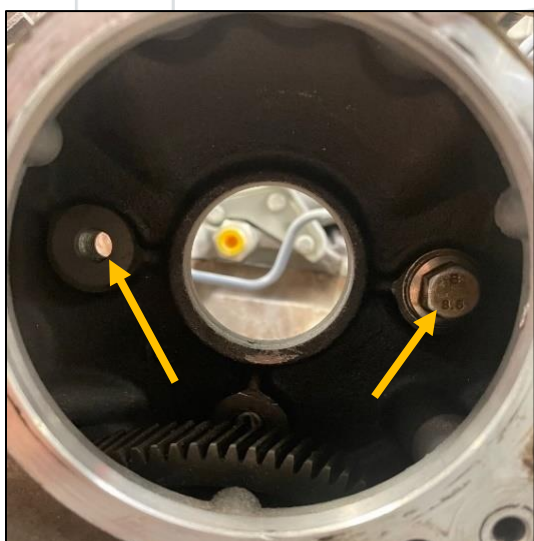

Figure 21: CP4 Mounting Bolt Locations

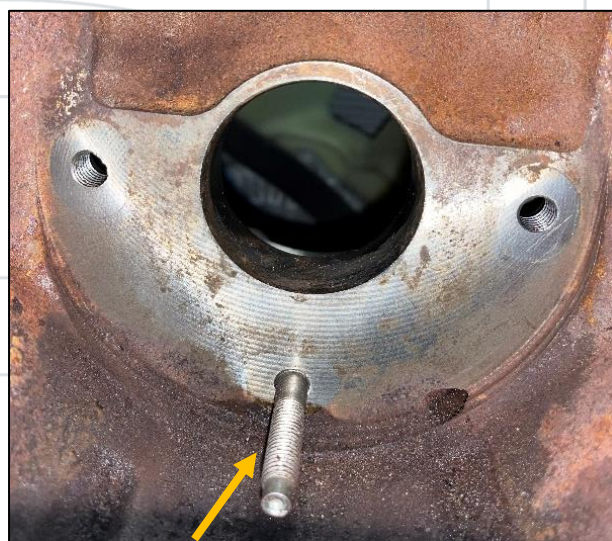

Figure 22: Pump Mounting Surface Cleanliness

2. Use a rag with a cleaning solvent and clean the area where the CP4 pump was located (Figure 22).
  - a. Use a razor blade or other flat scraper to ensure the surface is completely flat and free of debris. This will allow the DCR pump engine adapter plate to sit flush against the engine block. **It is critical for this surface to be clean and flat for proper pump alignment.**
3. Install the DCR Pump Adapter Plate to the Engine Block (Figure 24).
  - a. **Thread Check:** Hand thread the two countersink bolts into the block prior to installing the mounting plate. If the bolts do not thread with ease, use a M10x1.5 thread chasing tool to clean up the threads in the block. If the proper tool is not available, use the Torx bolts to chase the threads prior to final install.
  - b. Apply blue thread-locker on the threads of the two T45 Torx countersink bolts (Figure 23 – [see next page](#)).
  - c. Apply oil, grease, or assembly lube on the tapered head of the T45 Torx bolts to reduce friction during assembly (Figure 23 – [see next page](#)).
  - d. Tighten the two T45 Torx bolts evenly.
    - i. Step 1 - Torque both to **10 lb-ft** in order to center the plate.
    - ii. Step 2 - Once both are snug, final torque both to **42 lb-ft**.

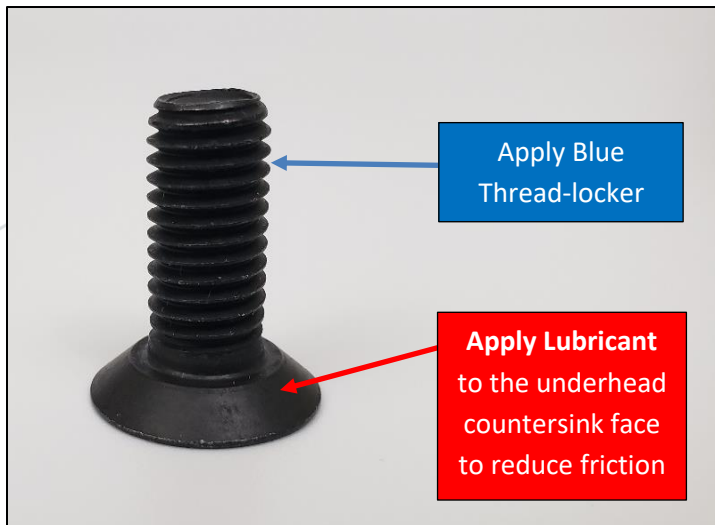

Figure 23: Countersink Bolts

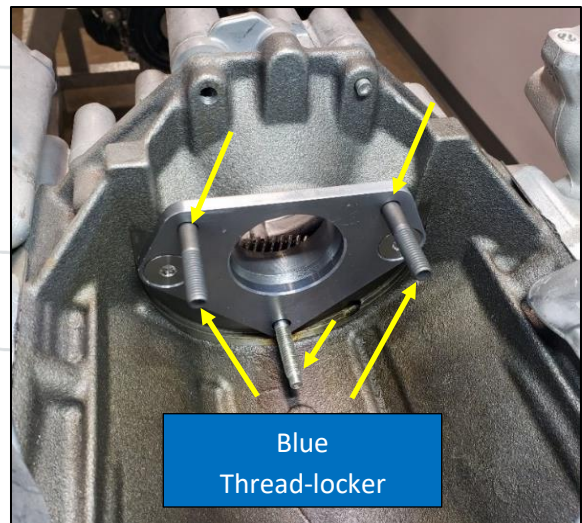

Figure 24: Engine Adapter Plate Installation on Engine Block

4. Apply blue thread-locker to the short, threaded side of the two S&S supplied mounting studs.
5. Install the short, threaded side of the mounting studs into the engine adapter plate (Figure 24).
  - a. Thread the studs into the adapter plate by hand until they are fully seated on the shank of the stud.
6. Apply blue thread-locker to all three DCR mounting studs shown in Figure 24.
7. Lubricate the pump's pilot flange O-ring with clean engine oil or o-ring lubricant.

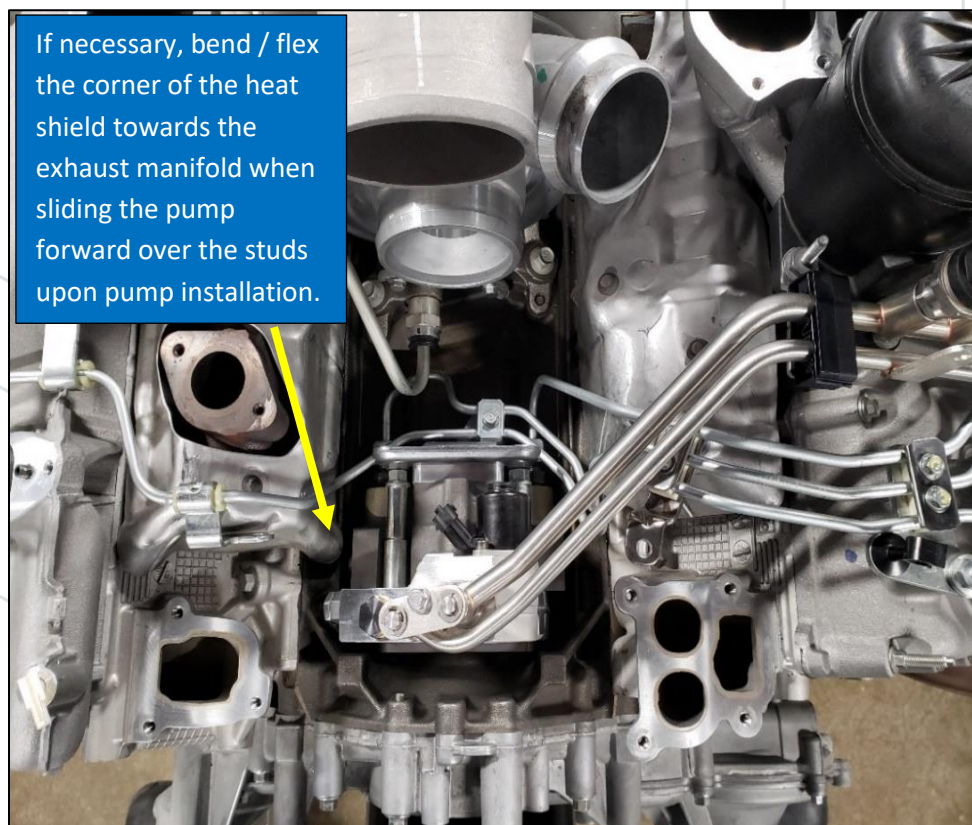

Figure 25: DCR Pump &amp; Lines Installed

8. Lower the DCR Pump into the valley with the pump shaft pointing downward towards the Adapter Plate pilot hole. Once the pump shaft is in the gear cover, align the pump with the 3 mounting studs and slide the pump forward.
- The high-pressure crossover line can be zip-tied towards the turbo to provide space to install the pump.
    - Do not** damage or excessively bend the rail-to-rail high pressure line while installing the pump.
  - If the pump is contacting the passenger side heat shield, it may be necessary to bend/flex the heat shield towards the exhaust manifold in order to provide clearance (Figure 25).
  - Push & wiggle the pump into the engine block until it is fully seated flush with the adapter plate.**
    - Do not use the mounting bolts to pull the pump into position as damage to the o-ring may occur.**
  - Install the OEM mounting nuts on all three studs and snug them evenly. Do not torque them until after the gear is installed & torqued.
9. **Fuel Pump Timing:** Turn the DCR pump shaft until the alignment pin is pointing straight up or in the 12 o'clock position as shown in Figure 26.
- Install the gear in the same orientation that it was removed with the double marks on the pump gear straddling the single mark on the engine's cam gear. Gear keyway at 12 o'clock as shown in Figure 27.

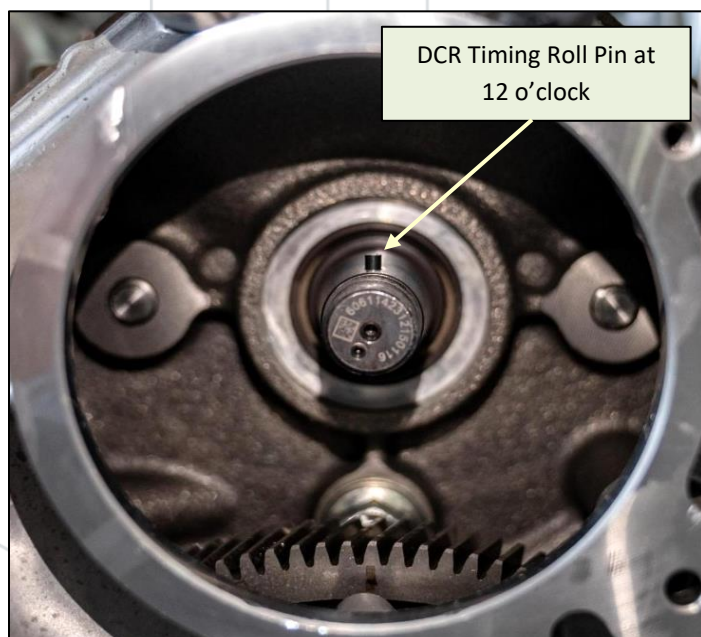

Figure 26: DCR Roll Pin at 12 o'clock

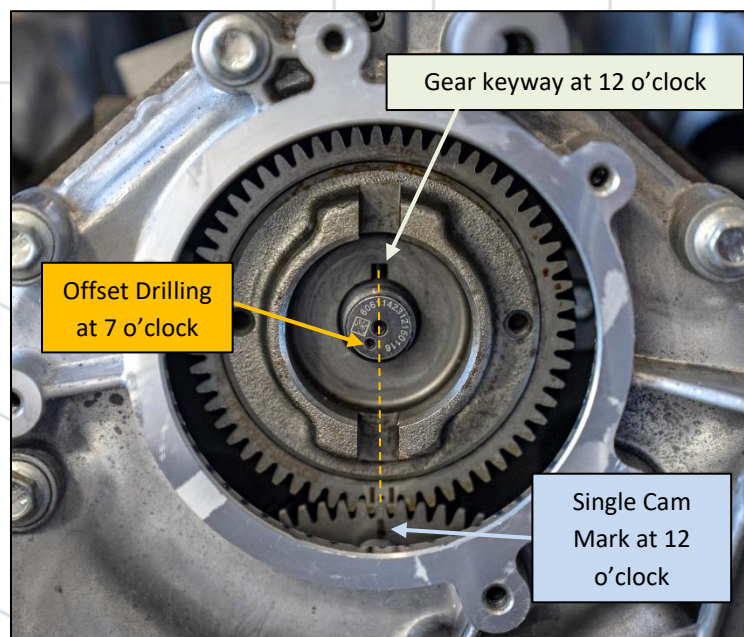

Figure 27: DCR Fuel Pump Timing

10. Torque the OEM fuel pump drive gear nut to the DCR pump shaft to **60 lb-ft (same as OEM CP4 spec)**.
- Hold the engine at the crankshaft damper bolts to prevent turning over if necessary. Typically, compression should hold the engine well enough to achieve 60 lb-ft.

## Pump Gear Clarification

Ford utilizes two different fuel pump gears. One is a 'full-width' gear that matches the width of the cam gear. The other is a '2/3 width' gear which results in the cam gear sticking proud of the fuel pump gear. In 2023, Ford went back to the 'full-width' gear. All model years spec the full-width gear if gear replacement is required. Either gear will work with the DCR pump.



Figure 28: MY 2011-2017, 23-24, & all replacement



Figure 29: MY 2017-2022 (2/3 width gear)

### 11. Use the three OEM pump mounting stud / nuts to secure the pump in place (Labeled as A in Figure 30).

a. To ensure proper alignment of the pump to the block, utilize the below two-step torque procedure.

- i. Torque all three to **10 lb-ft** starting with the bottom nut.
- ii. Torque all three to **18 lb-ft** starting with the bottom nut. **DO NOT over-torque these three nuts.**

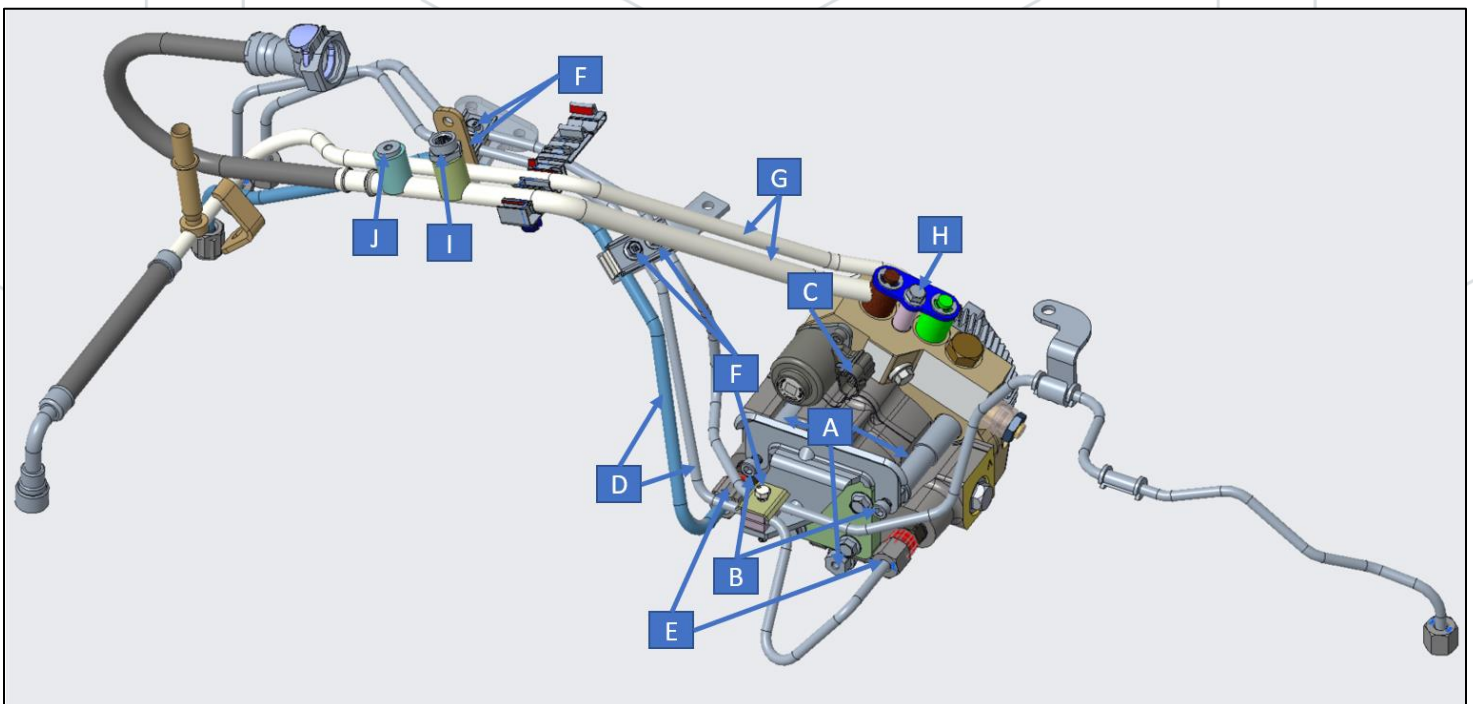

Figure 30: DCR Pump Assembly

**11. Referring to Figures 19, 25, and 30 (labeled as D), install the new high-pressure lines included in the kit.**

- a. Install the short driver-side high pressure line first, hand-tighten to the 3<sup>rd</sup> port on the driver's rail. Torque the nut on the pump to **26 lb-ft** prior to installing the longer passenger-side line.
- b. Install the passenger-side high pressure line, hand-tighten to the 2<sup>nd</sup> port on the rail and torque to **26 lb-ft** at the pump.
- c. Install the provided High-Pressure Fuel Line Tail Support Bracket to the OEM pump mounting nuts reusing the factory bolts (Labeled as B in Figure 30).
- d. Move the OEM rail to rail crossover line into the proper position and hand-tighten to the first port on the driver's side fuel rail.
- e. Install the bottom saddle on the pump's tail bracket that holds the crossover and passenger side lines.
- f. Install the triple line saddle brackets above the driver's side valve cover and heat shield & hand-tighten.
- g. Torque all remaining high pressure line nuts to **26 lb-ft** (Labeled as E). **3x Rail ports.**
- h. Torque saddle brackets starting with the pump's tail bracket & all hold-down brackets to **89 lb-in.**

**12. Install the vacuum pump.**

- a. [Install blue thread-locker on all four bolts.](#)
- b. Torque to **89 lb-in** (Figure 18).

**13. Install the cooling fan hub mounting assembly. Torque the five mounting bolts to 18 lb-ft (Figure 17).**

- a. **Do not install the upper right bolt until after the fan is installed as it is used to hold the fan clutch bracket.**

**14. Install the accessory belt. Exercise caution to ensure the belt seats properly on all pulleys (Figures 15 & 16).**

**15. Install the cooling fan. Torque the fan nut to 98 lb-ft.**

**16. Connect the cooling fan electrical connector & bracket to the fan hub using the remaining long bolt (Figure 17).**

**17. Connect the fuel control actuator (FCA / VCV) electrical connector to the pump (Labeled as C in Figure 30).**

**18. Depending on the model year of your truck, install the provided plug & adapter in the appropriate location in order to install the OEM sensors to the provided new low pressure line assembly:**

- a. **NOTE: In the model years where the plug is used, the plug has to be installed in the port closest to the rubber hose.** Plug - 7/16"-20 UNF Straight Thread O-Ring; Adapter - M12 x 1.5mm Straight Thread O-Ring

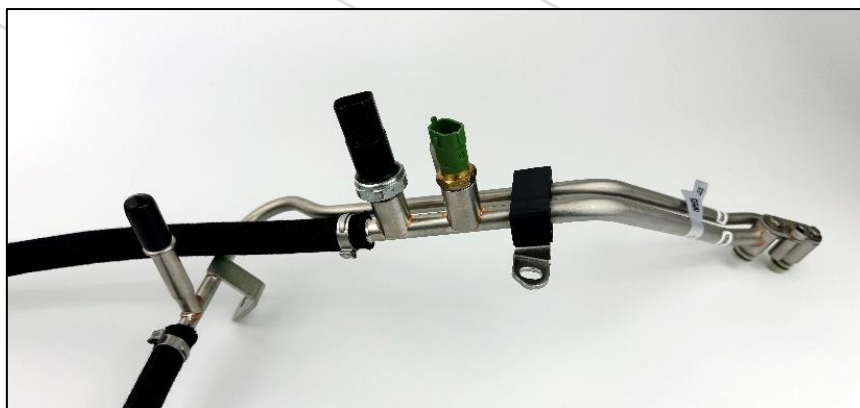

Figure 31: 2011-2014 (OEM Sensors: no plugs or adapters)



Figure 32: 2015-2019 (Plug, Adapter + OEM Sensor)



Figure 33: 2020+ (Plug &amp; OEM Sensor)



Figure 34: Reuse metal OEM bracket

**19. Remove the plastic line clip and metal bracket from the OEM low pressure line assembly.**

- a. The metal bracket must be reused. A new plastic clip is provided in case the OEM clip is damaged. You can use either the OEM or the S&S provided plastic clip upon assembly.

**20. Install the plastic clip and metal bracket to the new low pressure line assembly.**

**21. LUBRICATE the O-Rings of the low-pressure line assembly with clean Engine Oil or O-Ring Lubricant.**

**22. Install the supplied low-pressure line assembly into the DCR ports (Labeled as G in Figure 30).**

- a. Take care to ensure the o-rings are not cut during line assembly into the pump. To achieve this, push down and wiggle the LP line assembly during install to the pump. Press down on the LP line assembly until the lines are fully seated in the pump. **DO NOT use the OEM hold-down bolt to pull the line assembly into the pump as damage to the o-rings and bending of the flat plate will occur.**
- b. Install blue thread-locker on the line assembly to pump inlet OEM hold-down bolt (H in Figure 30)
- c. Torque the fuel line assembly to pump inlet to **89 lb-in** using the OEM hold-down bolt.
- d. Torque the low-pressure line assembly mounting point at the Valve Cover to **89 lb-in** using the OEM bolt.

**23. Referring to line A in Figure 11, make sure the return line is connected to the fuel rail quick connect securely.**

**24. Connect the pump return line to the fuel tank return line mounted on the engine (Labeled as C in Figure 11).**

**25. Connect the electrical connectors on the sensors of the new fuel supply lines (Labeled as I and J in Figure 30).**

**26. If equipped, reinstall the black fiber noise isolation cover on the driver's side valve cover.**

**27. Install the intake manifolds. (Both manifolds together for 2020+. Lower then Upper 'Step 36' for 2011-2019).**

- a. Torque 10mm head nuts/bolts to **18 lb-ft**. Torque 8mm head nuts/bolts to **89 lb-in**

**28. Connect the intake air throttle electrical connector.**

- k. On 2020+ the intake air throttle may have been unbolted to ease intake removal. Install if removed.

**29. Install the cold side intercooler pipe to the intake air throttle & intercooler (Labeled as L in Figure 8).**

**30. Install the fuel filter housing and fuel filter (Labeled as G in Figure 8).**

- k. S&S recommends replacing the factory engine and chassis fuel filters when the DCR pump is installed.

31. Connect the new S&S fuel supply line, OEM feed from tank, and OEM Injector Return to the fuel filter.
32. Install the crankcase ventilation hose to the lower intake manifold (Labeled as K in Figure 8).
33. Install the hot side intercooler pipe (Turbo to intercooler pipe) (Labeled as J in Figure 8).
34. Install the EGR bypass outlet pipe. Torque to 89 lb-in (Labeled as I in Figure 8).
35. Connect the EGR temp sensor located in the EGR bypass outlet pipe (Labeled as H in Figure 8).
36. Install the upper intake manifold (Labeled as F in Figure 8).
  - a. Tighten the bolts in the sequence shown in Figure 10 for 2011-2019 model years
  - b. Torque to 89 lb-in.
37. Connect the transmission and oil dipstick to the upper intake manifold (Labeled as E in Figure 8).
  - a. Torque to 89 lb-in.
38. Connect the coolant overflow tank hose and vacuum hoses.
39. Connect the coolant hose retainer to the upper intake manifold (Labeled as D in Figure 8).
40. Connect the MAP sensor electrical connector on the top of the upper intake manifold (Labeled as C in Fig 8).
41. Install the air filter intake and connect the MAF sensor (Labeled as B and A in Figure 8, respectively).
42. Connect the negative battery leads to both batteries.
43. **DO NOT attempt to start the engine without first priming the system by cycling the key multiple times.**
  - a. Turn the key to the ON position for 30 seconds. Cycle the key on (for 30 seconds each time) and off five times.
    - i. For vehicles equipped with a push-button start, press the button without your foot on the brake pedal.
44. After cycling the key on and off at least five times for 30 second intervals each time, start the truck and inspect the high and low-pressure fuel fittings for leaks.
45. Install the provided CARB EO sticker where it is easily visible in the engine bay.
  - k. **This kit is CARB approved for Model Years 2011-2023 only.**